

BL-1099

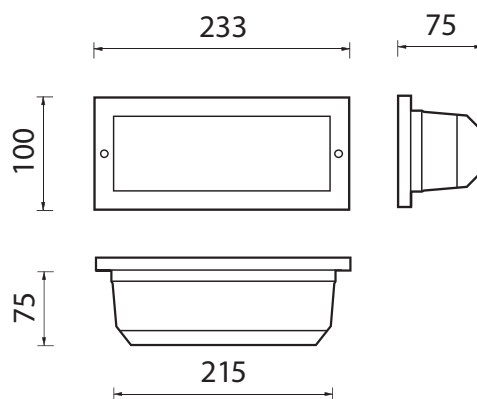

BL-1099.00X

Lamp: C35
Power: 40W
Base: E14

BL-1099.91X

Lamp: TC
Power: 9W
Base: G23

BL-1099.88X

Lamp: 2 x White LED
Power: 8.2W
LED: 460lm 6300K

Available Colours:

X=2 White X=9 Anthracite
X=3 Black X=4 Silver

- Recessed wall luminaire
- Die-cast aluminium body and ring
- Satin tempered glass diffuser
- EPDM gasket for Gamma Big and silicon gasket for
- Technopolymer wall holder
- Stainless steel screws
- Painting using high resistance to UV and corrosion polyester powders

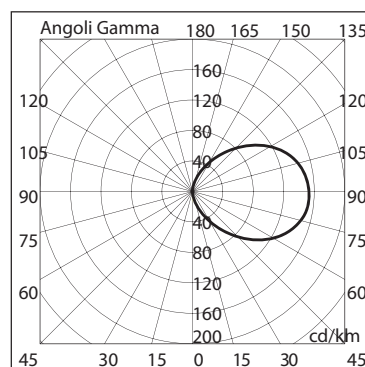

1099 00



Domus Lighting

29-31 Richland Street Kingsgrove NSW 2208
Phone: (02) 9554 9600 | Fax: (02) 9554 9433 | Email: sales@domuslighting.com

