

BL-1091

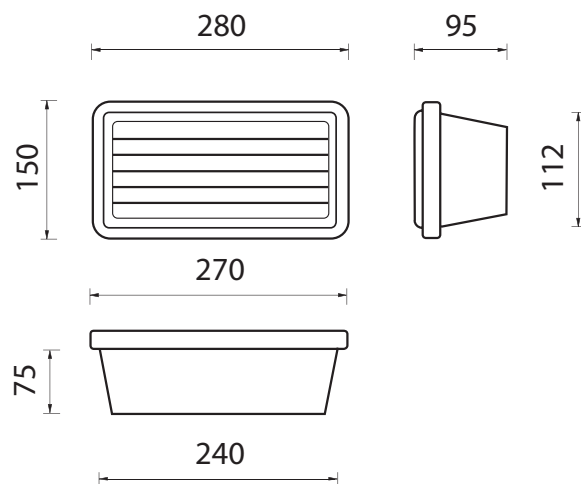

BL-1091.00X

Lamp: A60
Power: 60W
Base: E27

BL-1091.96X

Lamp: TC-D
Power: 18W
Base: G24 d-2

BL-1091.95X

Lamp: TC-D
Power: 26W
Base: G24 d-3

Colours

X=2 White X=9 Anthracite
X=3 Black X=4 Silver

- Recessed wall luminaire
- Die-cast aluminium body and ring
- Satin tempered glass diffuser
- EPDM gasket
- Technopolymer wall holder
- Stainless steel screws
- Painting using high resistance to UV and corrosion polyester powders

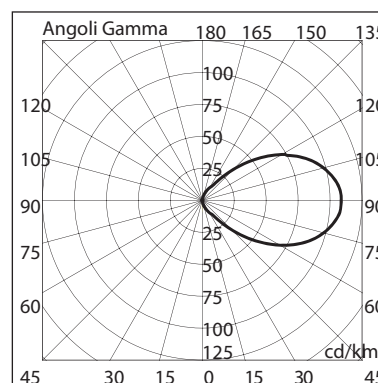

1091 00



Domus Lighting

29-31 Richland Street Kingsgrove NSW 2208

Phone: (02) 9554 9600 | Fax: (02) 9554 9433 | Email: sales@domuslighting.com