

BL-1072

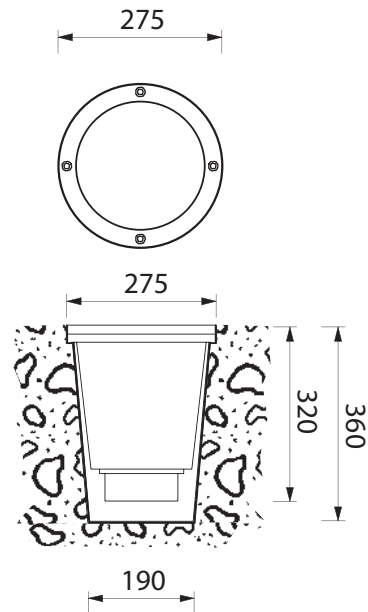

BL-1072.710

Lamp: HME

Power: 80W

Base: E27

- Outdoor recessed ground luminaire
- Painted die-cast aluminium structure
- Stainless steel AISI 316
- Die-cast aluminium diffuser grid (on request)
- Transparent or satin glass diffuser
- Aluminium reflector
- Silicon gaskets
- Stainless steel screws
- Technopolymer holder
- Painting using high resistance to UV and corrosion polyester powders

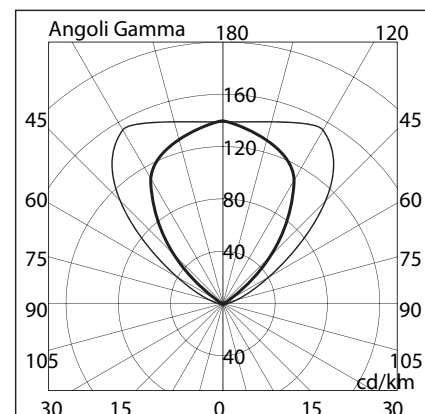

1072 71



Domus Lighting

29-31 Richland Street Kingsgrove NSW 2208

Phone: (02) 9554 9600 | Fax: (02) 9554 9433 | Email: sales@domuslighting.com