

BL-1040

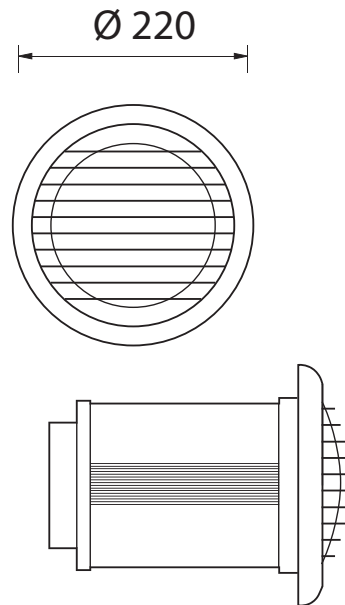

BL-1040.71X

Lamp: HME
Power: 80W
Base: E27

Available Colours:

X=2 White X=9 Anthracite
X=3 Black

- Ground luminaire
- Die-cast aluminium structure
- Transparent tempered glass diffuser
- Aluminium reflector
- Silicon gaskets
- Stainless steel screws
- Polypropylene holder
- Painting using high resistance to UV and corrosion polyester powders

