

# BL-1034

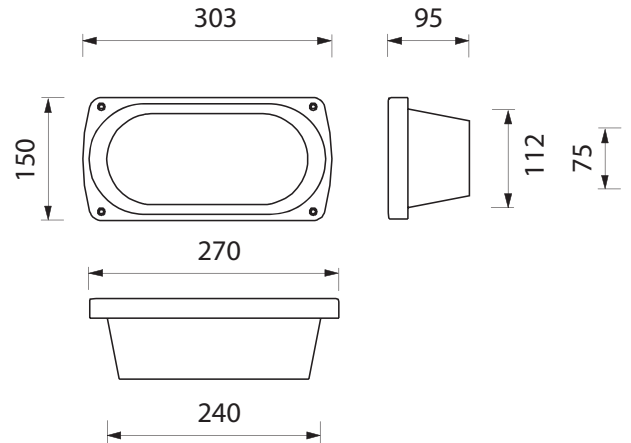

### BL-1034.00X

Lamp: A60  
Power: 60W  
Base: E27





### BL-1034.96X

Lamp: TC-D  
Power: 18W  
Base: G24 d-2

### BL-1034.95X

Lamp: TC-D  
Power: 26W  
Base: G24 d-3

### Colours

X=2  White    X=9  Anthracite  
X=3  Black    X=4  Silver



- Recessed wall luminaire
- Die-cast aluminium structure
- Satin tempered glass diffuser
- Technopolymer wall holder
- Stainless steel screws
- Painting using high resistance to UV and corrosion polyester powders

## Domus Lighting

29-31 Richland Street Kingsgrove NSW 2208

Phone: (02) 9554 9600 | Fax: (02) 9554 9433 | Email: sales@domuslighting.com