

BL-1031

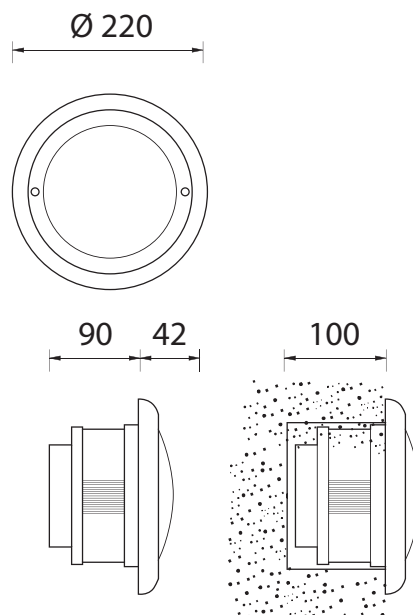

BL-1031.00X

Lamp: C35
Power: 40W
Base: E14

BL-1031.92X

Lamp: TC-D
Power: 10W
Base: G24 d-1

Available Colours:

X=2 White X=9 Anthracite
X=3 Black

- Recessed ground luminaire
- Die-cast aluminium structure
- Satin tempered glass diffuser
- Aluminium reflector
- Silicon gaskets
- Stainless steel screws
- Technopolymer holder
- Painting using high resistance to UV and corrosion polyester powders

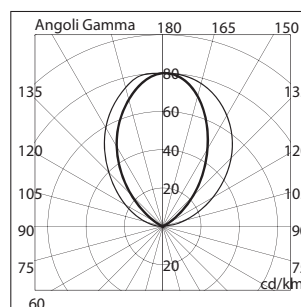

1031 92



Domus Lighting

29-31 Richland Street Kingsgrove NSW 2208

Phone: (02) 9554 9600 | Fax: (02) 9554 9433 | Email: sales@domuslighting.com