

# BL-1016

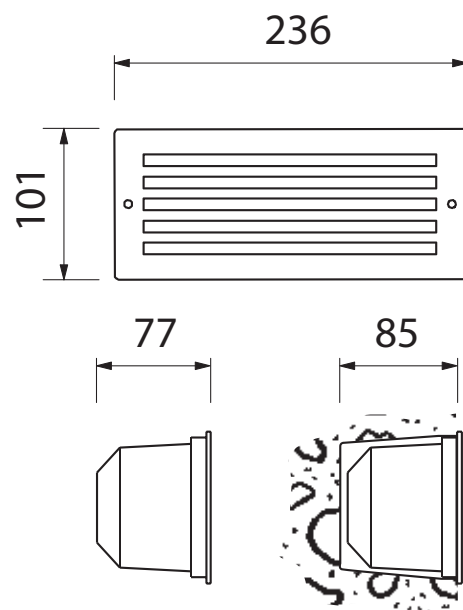

<b>BL-1016.000</b>	<b>BL-1016.910</b>	<b>BL-1016.880</b>
Lamp: C35	Lamp: TC	Lamp: 2 x White LED
Power: 40W	Power: 9W	Power: 8.2W
Base: E14	Base: G23	Base: 460lm 6300K

- Indoor and outdoor recessed wall luminaire
- Die-cast aluminium structure
- Stainless steel cover AISI 316
- Tempered opal glass diffuser
- Silicon gaskets
- Technopolymer wall holder
- Stainless steel screws
- Painting using high resistance to UV and corrosion polyester powders

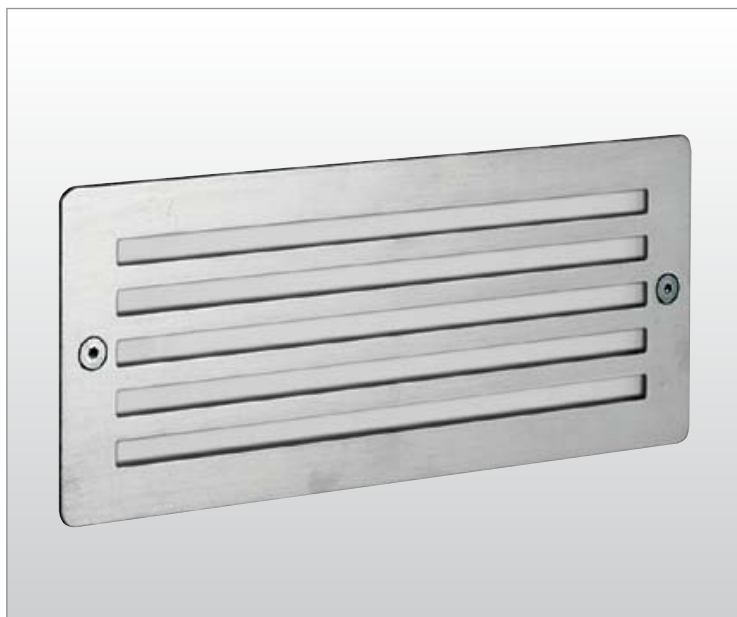
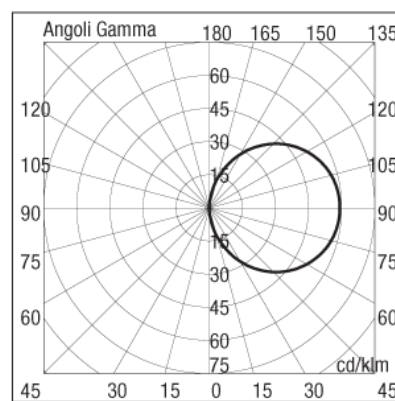

**1016 00**

