

# LUTA 316 Stainless Steel Adjustable LED Inground Lights



## PRODUCT SPECIFICATIONS

**Name:** LUTA

**Material:** 316 Stainless Steel face  
with Aluminium Body

**Colour:** Stainless Steel

**Trafficable:** 1000kgs

**Tilt:** 30°

**IP Rating:** IP67

**Lamp Base:** MR16

**CRI:** ≥80

**Wiring:** Parallel

**Dimmable:** No

**Warranty:** 2 years replacement\*\*

**NOTE:** adequate drainage must be allowed when installed

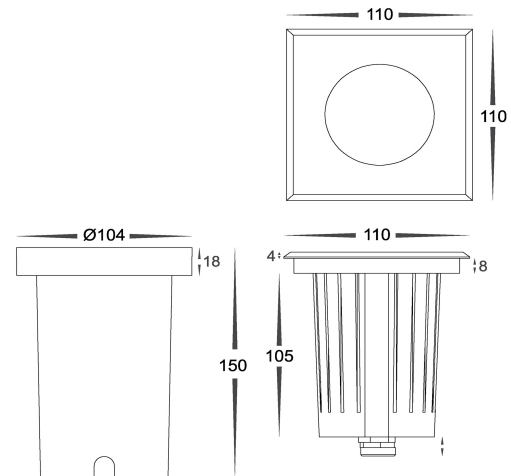

PART NUMBER	COLOUR TEMP	LUMENS	INPUT VOLTAGE	BEAM ANGLE	INCLUDED GLOBES
HV1825C-SQ	5500K	300lm	12v DC	120°	5w MR16 LED
HV1825W-SQ	3000K	250lm	12v DC	120°	5w MR16 LED

Must be used with suitable 12v DC LED driver

\* Lumen output measured at source

\*\* See Warranty Terms and Conditions for more information

For more information contact Havit Lighting

ADDRESS:  
143 Beauchamp Road  
Matraville NSW 2036  
Australia

Tel: 02 9381 8300  
Fax: 02 9666 8881  
Email: sales@havit.com.au  
web: www.havit.com.au