



SENSOR SMS830

Microwave motion ON/OFF sensor IP20

Application

Versatile microwave ON/OFF sensor. SAL factory fitted sensor option for approved products only, not for individual sale

Design Specifications

- Power source: 220-240V/AC
- Power frequency: 50/60Hz
- Transmission power: <0.2m/W
- Rated load: 1000W/5A, Max. incandescent lamp (cosφ=1) 300W/2.5A, Max. fluorescent lamp and LED lamp (cosφ=0.5)
- HF system: 5.8GHz CW electric wave, ISM band
- Detection angle: 360°



Performance

In Built Sensor - **YES**
Sensor Type - **MICROWAVE**

Technical Specification

Model No.	Description	Input Voltage (V/AC)	Power (W)	Body Colour
SMS830	NOT FOR INDIVIDUAL SALE	240	1000	WHITE

Due to continued product and technology enhancements, data sourced from sal.net.au shall not form part of any contract and or technical performance guarantee unless expressly confirmed in writing by SAL at the time of order. Products are sold in accordance with [SAL Terms and Conditions of sale](#) and all images shown are for illustration purposes only and may vary from the actual colour or finish. Unless specifically stated, all IP ratings nominated for Interior products are from "below the ceiling".

Dimensions

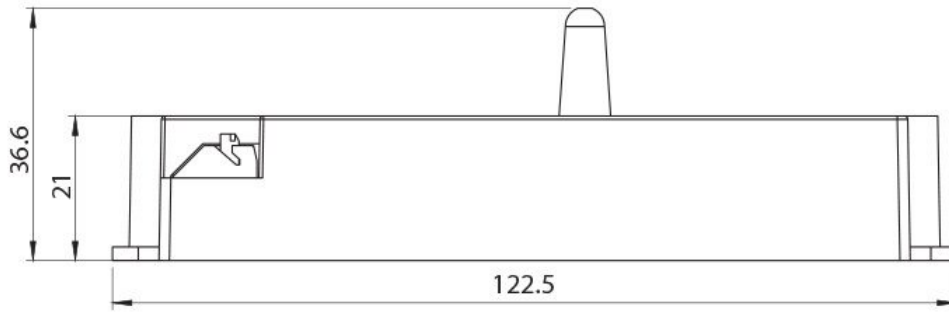

Width 29 mm

MODEL NO: SMS830

S1	S2	S3	S4	S5	S6
1 (ON)					
0 (OFF)					
SENS: S1, S2		TIME: S3, S4, S5		LUX: S6	

S1	S2	DETECTION RANGE
0	0	25%
0	1	50%
1	0	75%
1	1	100%

S3	S4	S5	TIME
0	0	0	10 s
0	0	1	1 min
0	1	0	3 min
0	1	1	5 min
1	0	0	10 min
1	0	1	15 min
1	1	0	20 min
1	1	1	30 min

S6	LUX
0	24 H
1	10 LUX

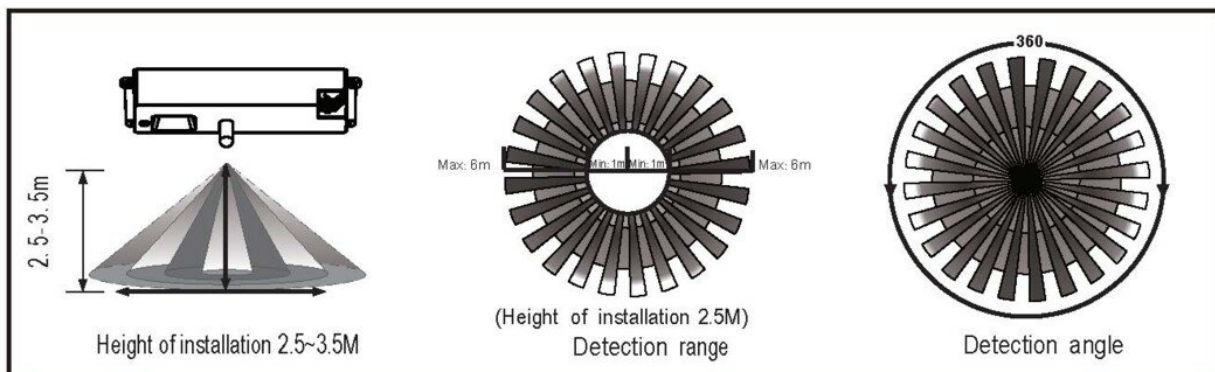

Product Images

