



SENSOR SMS733

Microwave motion sensor IP20 with step dimming

Application

Versatile residential and commercial sensor. SAL factory fitted sensor option for approved products only, **not for individual sale**

Design Specifications

- Operating voltage: 220~240Vac, 50/60Hz, rated load: 800W
- HF system: 5.8GHz ± 75MHz, ISM wave band, transmitting power: <0.5mW, power consumption: ≤1.0W (standby)
- Detection zone: Max.(D x H): 12m x 12m, detection sensitivity: 10%/25%/50%/75%/100%
- Hold time: 5s/30s/90s/3min/20min/30min, daylight sensor: 5lux/10lux/30lux/50lux/Disable
- Stand-by period: 5s/5min/10min/30min/1h/Disable, stand-by dimming level: 10%/20%/30%/40%/50%
- Mounting height: Max.12m, motion detection: 0.5~3m/s, detection angle: 150° (wall installation), 360° (ceiling installation)



Performance

Dimmable - **YES**

Dimmer Type - **Step dimming**

In Built Sensor - **YES**

Sensor Type - **MICROWAVE**

Technical Specification

Model No.	Description	Input Voltage (V/AC)	Power (W)
SMS733	MW Motion Sensor 1-10V DIM	240	800

Due to continued product and technology enhancements, data sourced from sal.net.au shall not form part of any contract and or technical performance guarantee unless expressly confirmed in writing by SAL at the time of order. Products are sold in accordance with [SAL Terms and Conditions of sale](#) and all images shown are for illustration purposes only and may vary from the actual colour or finish. Unless specifically stated, all IP ratings nominated for Interior products are from "below the ceiling".

Dimensions

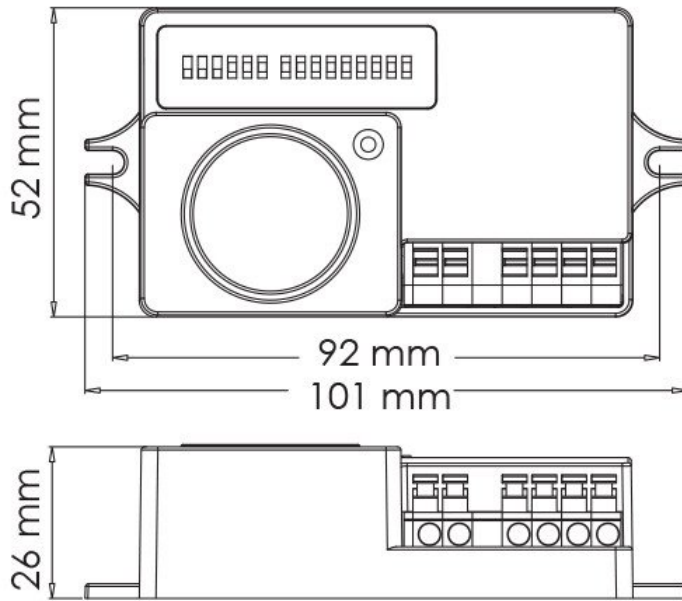

Product Images

Defection range

