

LED COMMERCIAL FLOOD LIGHT

SE7199 BRIGHT STAR

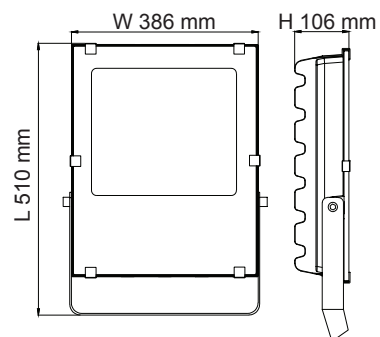

DIMENSIONS

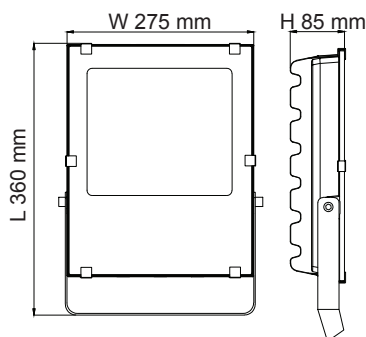

CONSTRUCTION

- Premium grade aluminium body
- Powder coated finish
- Textured tempered glass cover
- High efficiency SMD LED chips
- Built-in constant current non-dimmable LED driver
- Angled bracket for easy installation
- 1.5 m 3 core rubber flex

IP RATING

- IP65 weatherproof

FITTING COLOUR

- Black

COLOUR TEMPERATURE

- 3000K Warm White
- 5000K Neutral Daylight

Model No.	Input	Power	Lumen	CCT	Beam Angle	CRI	Net Weight
SE7199/100WW/BK	240V	100W	9500lm	3000K	100°	>80	3.9 kg
SE7199/100NDL/BK	240V	100W	9500lm	5000K	100°	>80	3.9 kg
SE7199/200WW/BK	240V	200W	19000lm	3000K	100°	>80	8.1 kg
SE7199/200NDL/BK	240V	200W	19000lm	5000K	100°	>80	8.1 kg
SE7199/250WW/BK	240V	250W	22800lm	3000K	100°	>80	8.2 kg
SE7199/250NDL/BK	240V	250W	22800lm	5000K	100°	>80	8.2 kg

ACCESSORIES

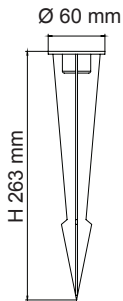

SE7099SPK/BK

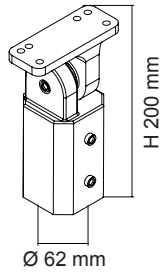

SE7099PMB/BK

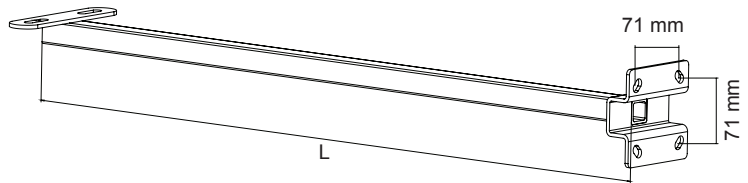

SE7099AMB/BK5, SE7099AMB/BK8, SE7099AMB/BK10

Model No.	Description	Dimensions
SE7099SPK/BK	Spike	Ø 60 mm x H 263 mm
SE7099PMB/BK	Pole mounting bracket (for SE7199/100 only)	Ø 62 mm x H 200 mm
SE7099AMB/BK5	Arm mounting bracket	L 500 mm
SE7099AMB/BK8	Arm mounting bracket	L 800 mm
SE7099AMB/BK10	Arm mounting bracket	L 1000 mm

PHOTOMETRIC DATA Unit: cd C0/C180 — C90/C270

SE7199/100NDL

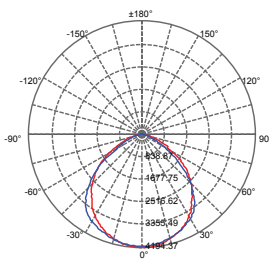

SE7199/200NDL

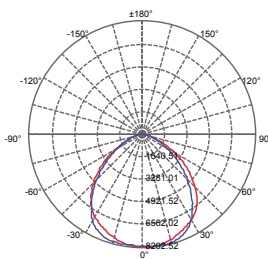

SE7199/250NDL

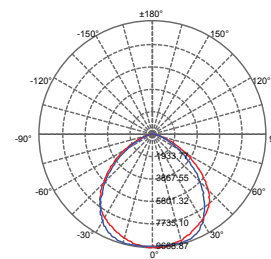

LED COMMERCIAL FLOOD LIGHT

SE7199 BRIGHT STAR

IP65



DIMENSIONS

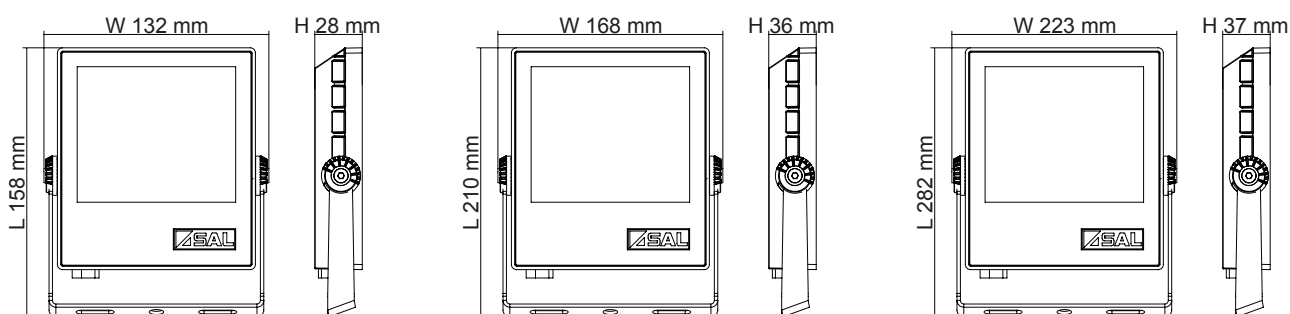

CONSTRUCTION

- Premium grade aluminium body
- Powder coated finish
- Textured tempered glass cover
- High efficiency SMD LED chips
- Built-in constant current non-dimmable LED driver
- Angled bracket for easy installation
- 1 m 3 core rubber flex

IP RATING

- IP65 weatherproof

FITTING COLOUR

- Black

COLOUR TEMPERATURE

- 3000K Warm White
- 5000K Neutral Daylight

Model No.	Input	Power	Lumen	CCT	Beam Angle	CRI
SE7199/20WW/BK	240V	20W	1400lm	3000K	110°	>80
SE7199/20NDL/BK	240V	20W	1600lm	5000K	110°	>80
SE7199/30WW/BK	240V	30W	2100lm	3000K	110°	>80
SE7199/30NDL/BK	240V	30W	2400lm	5000K	110°	>80
SE7199/50WW/BK	240V	50W	3500lm	3000K	110°	>80
SE7199/50NDL/BK	240V	50W	4000lm	5000K	110°	>80