



DRIVE SHP305 - 70/180W

70 - 180 watt, IP66 LED street luminaire, IK08 rated

Application

A decorative, streamline exterior commercial solution

Design Specifications

- Stylish die-cast aluminium body, durable powder coated Black finish as standard
- Integral constant current non-dimmable LED driver as standard, CCT 5000K standard, 4000K optional to order
- Asymmetrical light distribution (TYPE II) fitted, 0% upward light ratio, clear tempered glass diffuser
- Standard 3G.ANSI C.136.31-2010 Ø 60 pole mounting bracket, 800 mm 3 core rubber flex
- Optional integral constant current dimmable LED driver with 3 IN 1 dimming LED driver (1-10V DC, PWM signal & resistance)
- Lens option (refer to Photometric data below)
SHP305A75/P (standard), SHP305A45/P (option), optional PE cell configurations available

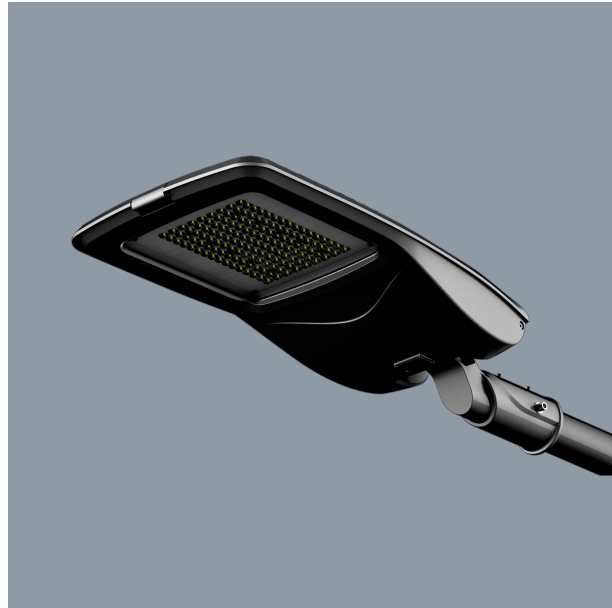

Performance

Dimmable - **OPTIONAL**
Dimmer Type - **1-10V DC**
In Built Sensor - **OPTIONAL**

Technical Specification

Model No.	Description	Input Voltage (V/AC)	Power (W)	Lumens (lm)	CCT (K)	CRI
SHP305/70NDL/BK	LED STREET LGT 70W 5K IP66 BK	240	70	8400	5000	70
SHP305/90NDL/BK	LED STREET LGT 90W 5K IP66 BK	240	90	10800	5000	70
SHP305/120NDL/BK	LED STREET LGT 120W 5K IP66 BK	240	120	14400	5000	70
SHP305/150NDL/BK	LED STREET LGT 150W 5K IP66 BK	240	150	18000	5000	70
SHP305/180NDL/BK	LED STREET LGT 180W 5K IP66 BK	240	180	21600	5000	70

Technical Specification

Model No.	Mass (kg)	Dim (mm)	Body Colour
SHP305/70NDL/BK	9.2	763(L) x 352(W) x 167(H)	BLACK
SHP305/90NDL/BK	9.2	763(L) x 352(W) x 167(H)	BLACK
SHP305/120NDL/BK	9.2	763(L) x 352(W) x 167(H)	BLACK
SHP305/150NDL/BK	9.2	763(L) x 352(W) x 167(H)	BLACK
SHP305/180NDL/BK	9.2	763(L) x 352(W) x 167(H)	BLACK

Due to continued product and technology enhancements, data sourced from sal.net.au shall not form part of any contract and or technical performance guarantee unless expressly confirmed in writing by SAL at the time of order. Products are sold in accordance with [SAL Terms and Conditions of sale](#) and all images shown are for illustration purposes only and may vary from the actual colour or finish. Unless specifically stated, all IP ratings nominated for Interior products are from "below the ceiling".

Dimensions

SHP305

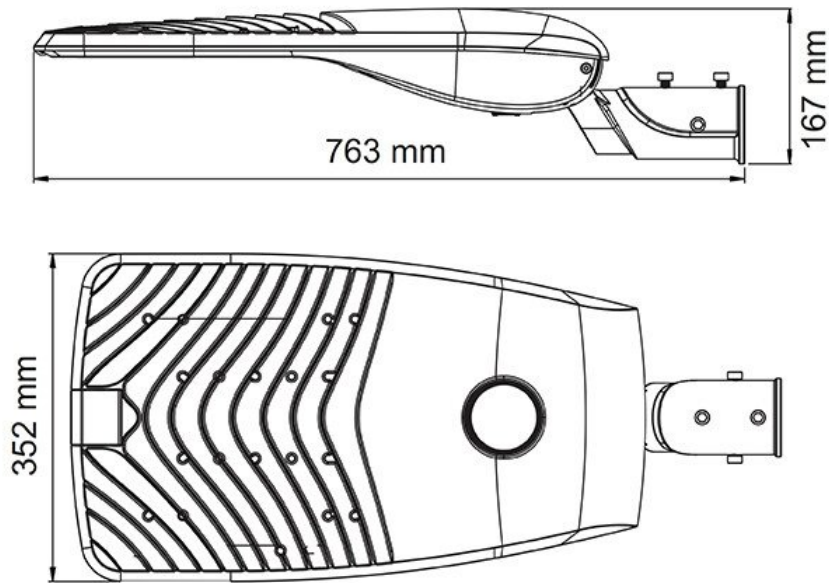

Photometric Data

Unit: cd C0/C180 _____ C90/C270 _____

**SHP305/70NDL at 5000K
with SHP305A75/P**

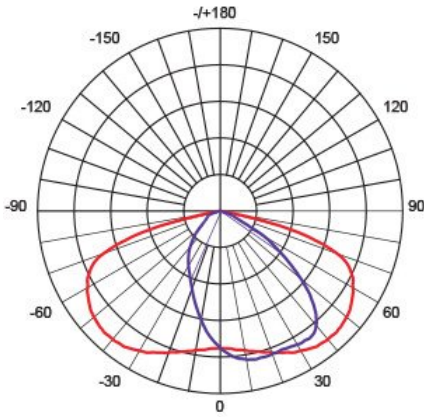

**SHP305/180NDL at 5000K
with SHP305A45/P**

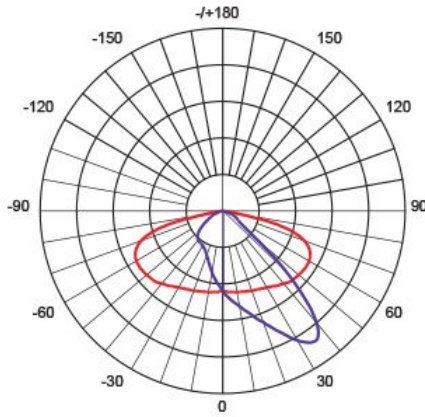

Product Images



SPIGOT OPTIONS (BLACK SHOWN)

Ø 34mm



Ø 42mm



Ø 76mm



BRACKET OPTIONS (BLACK SHOWN) Ø 60mm spigot

Wall bracket



Corner bracket



L-bracket



T-Bracket

