

# Tenac Aluminium Black Wall Light

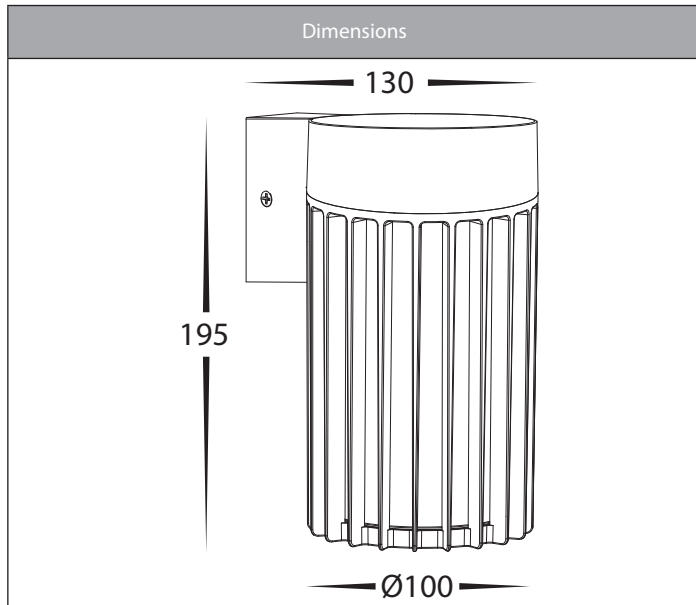

## Product Specifications

Name	Angela
Material	Aluminium
Colour	Poly Powder Coated Black or White
IP Rating	IP54
Installation Type	Wall - Surface Mounted
Lamp Base	E27
Protection Class	240v = 1 (Requires Earth)
Max Wattage	9w
Lamp Expectancy	<30,000hrs
Diffuser Type	Opal PC
CRI	CRI>80
Dimmable	No
IK Rating	IK06
Warranty	3 Years Replacement*



## Product Ordering

Image	Part Number	Colour Temp	Lumens	Input Voltage	Beam Angle	Included LED	Barcode
	<b>HV3693T-BLK</b>	3000k 4000k 5500k	700lm 740lm 720lm	240v AC	180°	<b>TRI Colour</b> 9w E27 LED	9350418038289

\*Items ordered after 01-01-2022

Havit Lighting  
143 Beauchamp Road,  
Matraville, N.S.W. 2036

Phone: 02 9381 8300  
Email: sales@havit.com.au  
Web: www.havit.com.au



Warranty Terms & Conditions



www.havit.com.au