

Eclipse

- Powerful ball bearing motor for superior reliability
- Tri-CCT LED panel provides energy-efficient illumination
- Enjoy quiet operation
- Supplied with flex and plug for easy DIY installation
- 3-year return to base warranty for peace of mind
- Draught stopper for improved energy efficiency



ORDERING INFORMATION

Order code	16759
Description	240mm 30W Ducted exhaust fan with round white fascia w/Light - Tri-CCT
Item Code	ECLIPSE/240/LT/WH/RD

MECHANICAL

Product Finish	Matt
Fitting Colour	White
IC Rating	Do not cover
Installation Type	Recessed
IP Rating	IPx4

ELECTRICAL

Electrical Rating	Class I
Input Frequency	50 Hz
Input voltage	230Vac
In Australia the Input voltage is defined as 230Vac -6%/+10%. This effectively means that the voltage range of these products are 216Vac - 253Vac or 240V +6%	
Working Temp Range	-10 to 40 °C

LAMP

CCT Configuration	TRI-CCT
Colour Rendering Index (CRI)	>80

COLOUR TEMPERATURE

12 Watts

Warm White (3000 K)	900 lm
Cool White (4000 K)	1000 lm
DayLight (5000 K)	900 lm

AIR MOVEMENT

Outlet	100 mm
Noise level	42 dB
Motor Wattage	30 W
Motor Type	Ball bearing
Fan Type	Centrifugal
Fan Size	240
Air extraction	270 m ³ /hr

DRIVER

Flex & Plug or Lead Length	900 mm
Wiring Type	Re-wireable Flex & Plug (3 pin)

COMPLIANCE

Product Design Life 10 years

The product design life relates to the total product life which includes LEDs, drivers and the enclosure. This is different to the LED lifetime which only refers to the economical lifetime of the LEDs at which time the lumen output has dropped below the L Value. The product design life is calculated at the maximum ambient or working temperature of the product and takes into account the Daily Use.

Daily Use 2 hrs

The Daily Use is the recommended time required to meet the product's design life. Installations can exceed this time, however the product design life will be reduced proportionally.

Standards AS/NZS 60335.1
AS/NZS 60335.2.80
AS/NZS 60598.1
AS/NZS 60598.2.2
AS/NZS CISPR 14.1
AS CISPR 15

WARRANTY

Domestic Use Warranty 3 RTB (Total 3 Years)

Warranty Operating Hours 2500 hrs

This product is provided with a warranty up until the stated warranty period or until the stated warranty operating hours has been reached (whichever occurs first).

DIMENSIONS

Minimum Ceiling Depth 220 mm

Cutout 240 mm

Product Height 195 mm

Product Length 270 mm

Product Width 270 mm

LINE DRAWINGS

ECLIPSE/240/LT/WH/RD

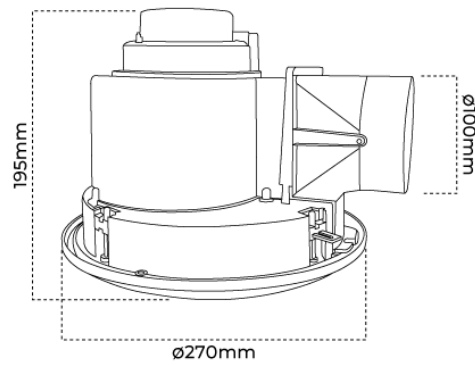

ACCESSORIES

Order code 12677

Description 125mm Duct Adapter to suit Small Eclipse

Item Code AT9492

Order code 16782

Description 240mm square exhaust fan fascia w/LED Light - matt white - Tri-cct

Item Code ECLIPSE/TRIM/240/LT/WH/S Q