

Last modification 2023-10-14

## ZELDIN EX40-BRS 9329501066171



The Zeldin Exterior Wall Lamp draws inspiration from traditional lanterns, infusing your outdoor space with classic elegance. Its distinguishing feature is the unique tile roof pressing on top, which adds a distinctive touch to its design. Crafted with care and attention to detail, this outdoor lamp is a blend of timeless aesthetics and modern functionality. Illuminate your surroundings with a touch of tradition and sophistication, courtesy of the Zeldin Wall Lamp. Available in black or brass and in 2 sizes.

### Overview

<b>Family name</b>	Zeldin
<b>Categories</b>	Coach Lights
<b>Mounting</b>	Surface
<b>Usage</b>	Outdoor Lighting

### Color / Material

<b>Fixture Color</b>	Brass
<b>Fixture Material</b>	Solid Brass

### Size

<b>Fixture Width (cm)</b>	18.0
<b>Fixture Height (cm)</b>	40.5
<b>Fixture Projection (cm)</b>	22.0

### Specification

<b>Voltage Input</b>	240V
<b>Total Wattage (max)</b>	25
<b>Globe Type</b>	E27
<b>Globe / Light Source qty</b>	1
<b>Globe / Light Source included</b>	No
<b>Electrical Protection</b>	CLASS I - HIGH VOLTAGE, EARTH REQUIRED
<b>IP rating</b>	IP43
<b>Lead and Plug</b>	No
<b>Approvals</b>	RCM
<b>Assembly Required</b>	No
<b>Installation Required</b>	Yes (by Licensed Electrician only)

All representations within this document are subject to copyright. ELECTRICAL INSTALLATIONS MUST BE PERFORMED BY A QUALIFIED ELECTRICAL CONTRACTOR AND INSTALLED IN ACCORDANCE WITH AS/NZS 3000.  
NOTE : All images , descriptions and dimensions are indicative. Please check latest version of item detail on Telbix website prior to ordering or installation.

**Care Instructions**

Do not use strong liquid cleaners, Wipe clean with a dry cloth

**Replacement Warranty**

\*3 Years

**Barcode****GTIN**

9329501066171

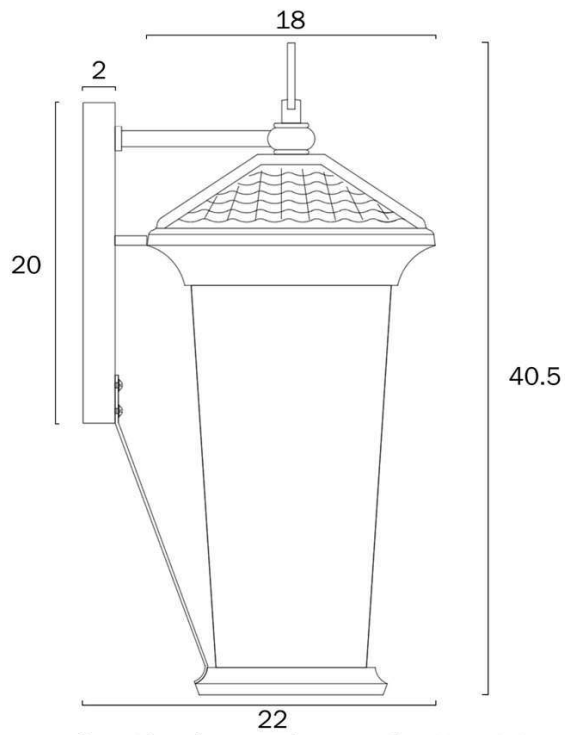
**Image -dimensions**

Note: Dimensions are only a guide and may vary due to manufacturing variations.

