

Last modification 2022-06-27

## AMPARO FL-BK 9329501061176



The Amparo Floor Lamp's elegant sophistication is inspired by the 1950s featuring silhouetted floating discs. Finished in satin black the Amparo will add a special touch to a contemporary interior. Place in the living room, office or on your bedroom.

### Overview

<b>Family name</b>	Amparo
<b>Categories</b>	Floor Lamps
<b>Switch</b>	Foot Switch
<b>Usage</b>	Indoor Lighting
<b>ERAC Product Registration</b>	SAA-210304-EA

### Color / Material

<b>Fixture Color</b>	Black
<b>Fixture Material</b>	Metal
<b>Base Color</b>	Black
<b>Base Material</b>	Metal
<b>Cable Color</b>	Black
<b>Cable Material</b>	PVC

### Size

<b>Fixture Diameter (cm)</b>	28.0
<b>Fixture Height (cm)</b>	160.0

### Specification

<b>Voltage Input</b>	240V
<b>Wattage (max)</b>	12
<b>Wattage</b>	6
<b>Globe Type</b>	G9
<b>Globe / Light Source qty</b>	2
<b>Globe / Light Source included</b>	No
<b>Dimmable</b>	Globe Dependant
<b>Electrical Protection</b>	CLASS II - DOUBLE INSULATED, EARTH NOT REQUIRED
<b>IP rating</b>	IP20

All representations within this document are subject to copyright. ELECTRICAL INSTALLATIONS MUST BE PERFORMED BY A QUALIFIED ELECTRICAL CONTRACTOR AND INSTALLED IN ACCORDANCE WITH AS/NZS 3000.  
NOTE : All images , descriptions and dimensions are indicative. Please check latest version of item detail on Telbix website prior to ordering or installation.

<b>Lead and Plug</b>	Yes
<b>Approvals</b>	RCM
<b>Assembly Required</b>	Yes
<b>Box Contents</b>	Instruction
<b>Care Instructions</b>	Do not use strong liquid cleaners,Wipe clean with a dry cloth
<b>Warranty</b>	3 Years

Barcode

**GTIN** 9329501061176

Image -dimensions

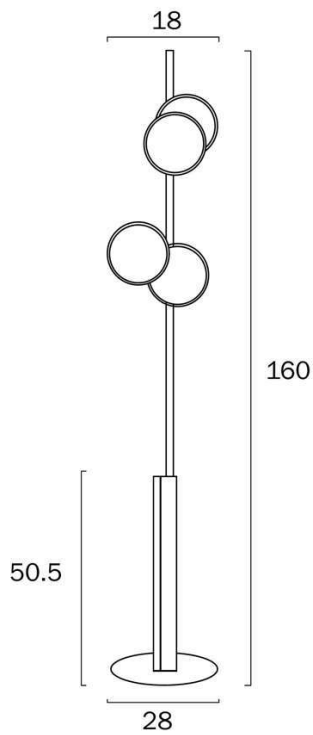

Note: Dimensions are only a guide and may vary due to manufacturing variations.

