

Industrial Range

Street Lights

Street Light w/ Integrated IP Camera

Product Code	LED's	Battery	Solar Panel	IP Rating	Lumens
SLDSTL-15W/CAM-SII	30 x 3030 LumiLED (Cool White)	1 x 11.1V 17.2Ah Li-Ion	18vDC 43W Integrated Polycrystalline	66	1500-1650 @ 1m

Features:

- All-In-One Construction
- Approximately 7 hour Charging Time
- Operating Time: 6 Hrs at 100% + 6 Hrs at 50%
- Strength & Durability Rating: IK08
- Aluminium Alloy & PMMA Construction

Camera Features:

- 3 Mega Pixels
- Pan, Tilt & Zoom lens control, 2.7-13.5mm Zoom
- 90* viewing angle with 360* rotation
- Internet Protocol (IP) with Wifi
- ONVIF Compatible
- Infrared Vision Technology
- 64GB TF Storage Card

2 Year Warranty!

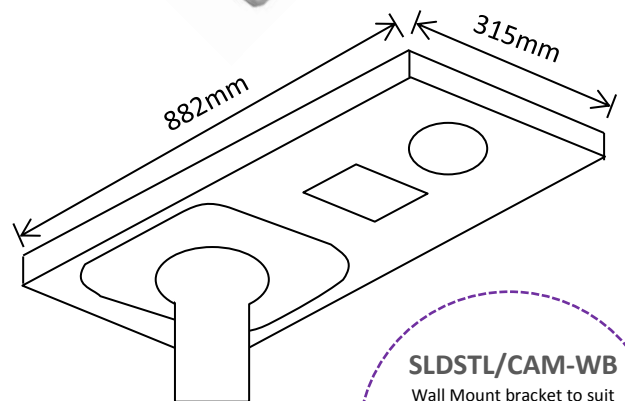

Internal Diameter – Ø76mm

SLDSTL/CAM-WB
Wall Mount bracket to suit
All-In-One Street Lights



Packaged Fitting Weight & Dimensions

W: 10.2kg

D: 95cm x 42cm x 17cm