

EV-MR16-ML-6W-W

Introducing the NEW MONO lens range of MR16 lamps.

The MONO lens MR16 lamp is specifically designed as a replacement for your traditional halogen lamps. It's as easy as removing the standard MR16 lamp and transformer and replacing it with the NEW MONO lens MR16 lamp and LED driver. The NEW Mono lens will look almost exactly the same as what you have just replaced.

The MONO MR16 lamp incorporates the latest Sharp COB (Chip on board) LED which is then matched with a specifically designed heat sink to disburse heat away from the LED.

This is the perfect lamp for areas where light levels are not critical or where a high quality budget lamp is required.



Sharp COB
chip inside

3 Year Replacement Warranty

Product Specifications:

Wattage:	6W
LED:	Sharp COB
Colour / lm:	White (5000K) 380lm
Light quality (CRI):	>83
Beam angle:	60°
IP rating:	IP20
Lifetime:	40,000hrs
Input Voltage:	12V DC
Recommended Driver:	DM1210
Dimmable:	No
Operating Temp:	-20° to 65°
Special Notes:	NOT to be used with standard halogen transformers

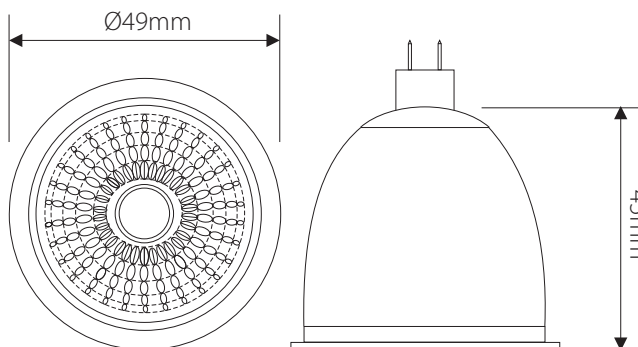

Product Code: **EV-MR16-ML-6W-W** | Order Code: **20476**



White 5000K

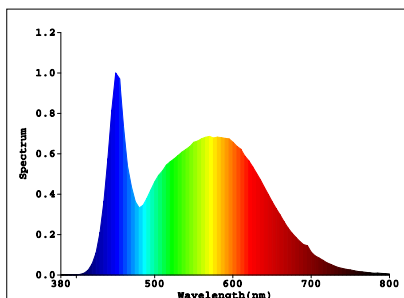

Quality
ISO 9001
SAI GLOBAL

Domus Lighting

29-31 Richland Street Kingsgrove NSW 2208

Phone: (02) 9554 9600 | Fax: (02) 9554 9433 | Email: sales@domuslighting.com