

Commercial Range

Wall Washers / Uplighters

In-Ground Uplighter

Product Code	LED's	Battery	Solar Panel	IP Rating	Lumens
SLDIG-2W	2 x Epistar 5050 LEDs @ 1Wea (Warm White)	1 x 12V 2Ah Lithium	6V Integrated Polycrystalline	65	180 @ 1m

Features:

- Stainless Steel Construction
- Approximately 6 hours Operation
- Max Walk Over Pressure - 100kg
- Recessed Mounting Position
- Tempered Glass
- Depth:
 - o Without Recessing Frame = 65mm
 - o With Recessing Frame = 90mm

2 Year Warranty!

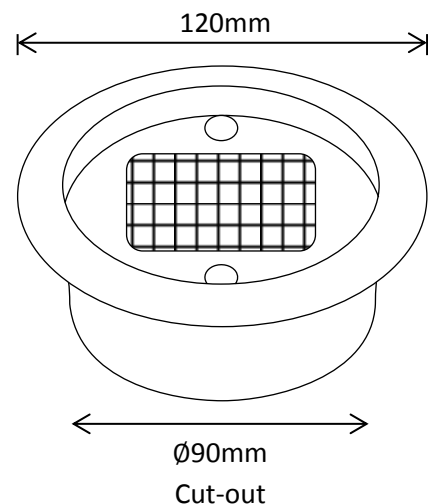

Packaged Fitting Weight & Dimensions

W: 0.7kg

D: 12.5cm x 12.5cm x 12cm